



The Smart Spaces Makers

Smart electrical networks

a modern usage of obsolete grids

Outline of today's lecture (1/2)



- Electric grid infrastructure and components
 - Production energy: from turbines-alternators to power
 - Historical sketch (AC vs DC)
 - 3-phase systems: technical features, advantages, measurements
 - Measurements for mono and 3-phase systems (Voltages, Currents, Phases)
 - Power Distribution from High to Low voltage (transformers, protection relays and other main components, loads classification, phase shift)
 - Actual grids: European and Italian standards
 - What makes old grids obsolete

Outline of today's lecture (2/2)



- Smart Grids
 - Key concepts (what “smart” means?)
 - Smart devices (meters, sensors, controllers)
 - “Smart” features (remote controlling, self healing, adaptive power routing, optimized power usage, local power generation)
 - Key strategies for power saving
 - examples
 - *importance of remote maintenance (video)*
 - *self healing*

Producing electric energy

- Electrical energy is not present in nature in significant amounts
- Easy to create, transfer and convert

Primary sources:

- Coal
- Oil
- Gas
- Nuclear
- Biomass & Waste
- Hydro
- Wind
- Solar
- Geothermal

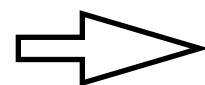

Electrical energy



Energy Grid

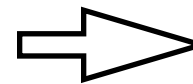

Kinetic energy
Lights
Heating
ecc...

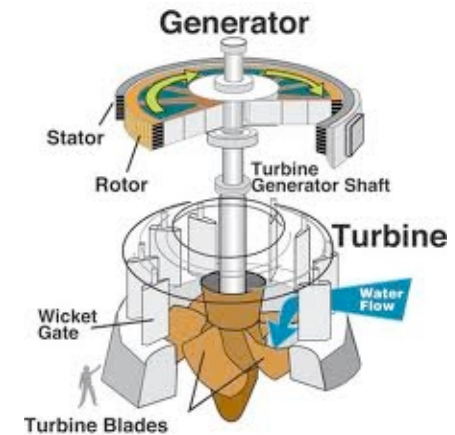

History: AC vs DC

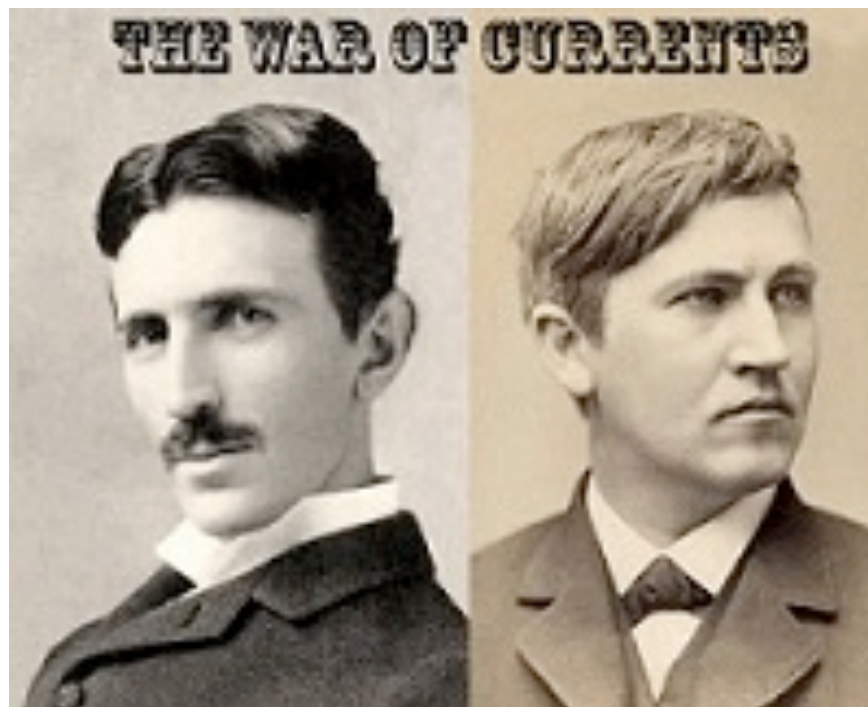

Nikola Tesla
1856-1943

AC inventor

Thomas Edison
1847-1931

DC inventor

- Economic challenge of the XIX century
- Related to the second economic revolution

History: AC vs DC

- Direct current
 - constant current and voltage amplitude and direction (polarity)
 - devices work with DC
 - produced by dinamos
 - easy to store in batteries

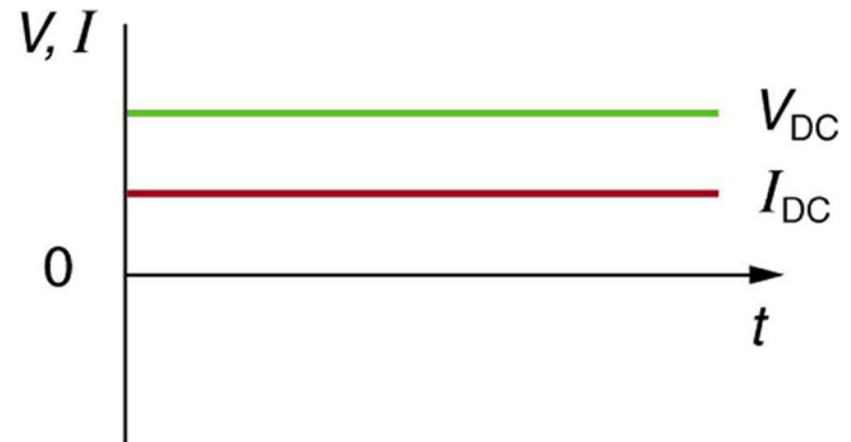

History: AC vs DC

- Alternating current
 - current and voltage are sine waves at constant frequency
 - easy to produce (using Alternators)
 - Voltage is easy to increase and decrease (using transformers)
 - easy to transform to DC (using Rectifiers)

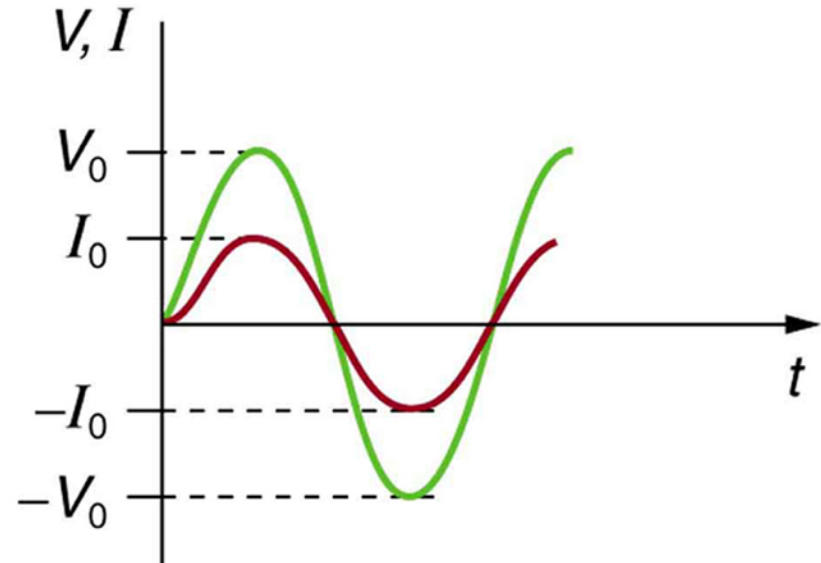

Definitions and calculations

- Measurement in AC

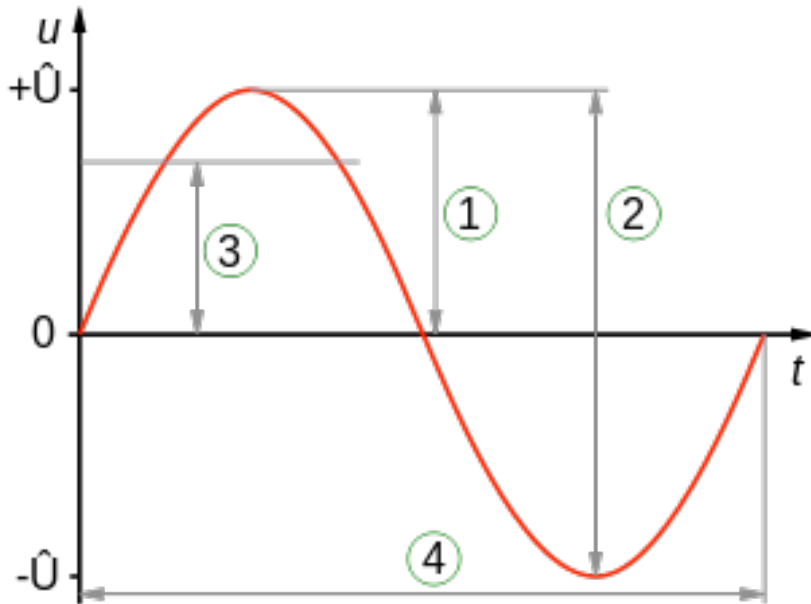

$$v(t) = V_{\text{peak}} \cdot \sin(\omega t)$$

$$\omega = 2\pi f$$

1 - Amplitude (peak)

2 - Peak to peak

3 - RMS value

4 - Wave period

$$V_{\text{rms}} = \sqrt{\frac{1}{T} \int_0^T v^2(t) dt.}$$

$$V_{\text{rms}} = \frac{V_{\text{peak}}}{\sqrt{2}}.$$

AC for energy distribution

- DC current suffers high power dissipation
- $P = V \cdot I$
- Metal conducting wires have an almost fixed electrical resistance
- Power loss is given by Joule's first law and is proportional to the square of the current

$$Q \propto I^2 \cdot R$$

- **Low-current, high-voltage** transmission is the best way to transfer the power

Three phase systems (1/3)

- Three-phase AC became the most economical transmission method
- Use of three conducting lines carrying alternating current voltages that are offset in time by one-third of the period

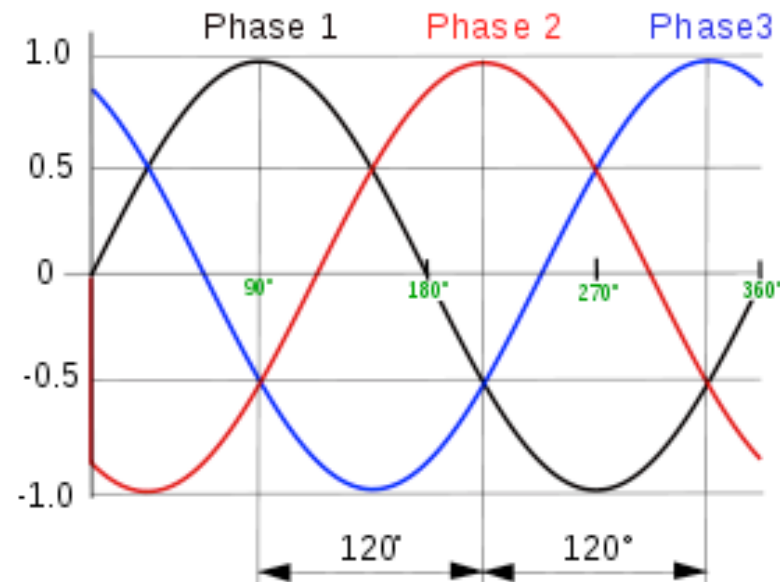

Three phase systems (2/3)

- Three-phase symmetrical balanced system
- Three mono-phase generators (same frequency)
 - Three main advantages
 - *conductors optimization*
 - *less power loss*
 - *easy production of rotating magnetic fields*

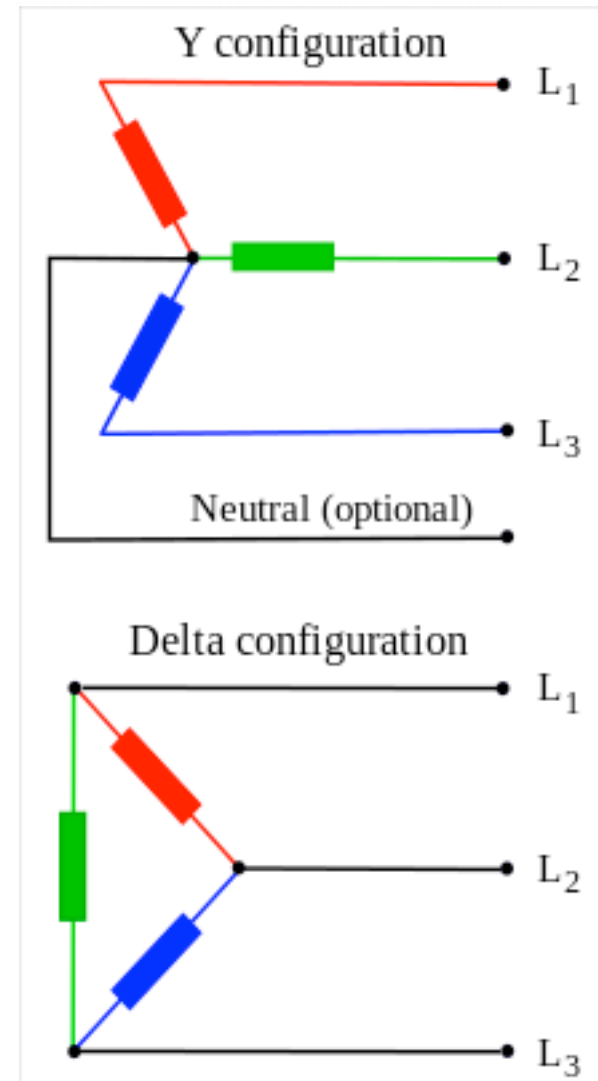

Three phase systems (3/3)

- delay between phases has the effect of giving constant power transfer
- for **symmetric** and **balanced** systems at time t :
 - *sum of all concatenated voltages is $\mathbf{0}$ for Δ configuration*
 - *vector sum of voltages of the neutral point is $\mathbf{0}$ for Y configuration*
 - *sum of currents from each phase is 0 (neutral can be avoided)*



- *measurements are sums of monophasic values*
- *e.g. $P_{123} = P_1 + P_2 + P_3$*

Electrical grid (1/2)

- production network: generation and high voltage transmission
- distribution network: medium and low voltage distribution
- based on voltage jumps (transformers)

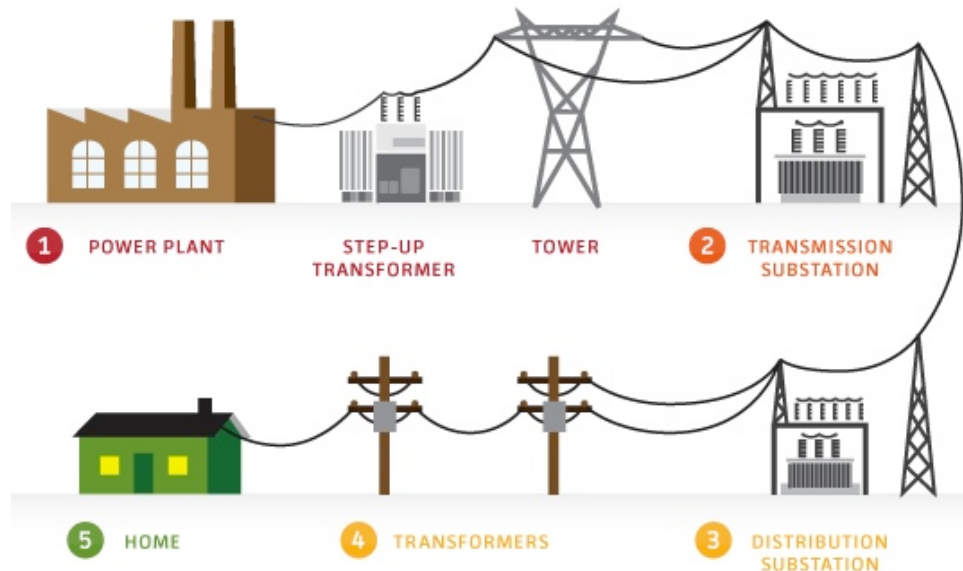

HV = 60kV - 150kV

MV = 1kV - 30kV

LV = 50V - 1kV

Electrical grid (2/2)

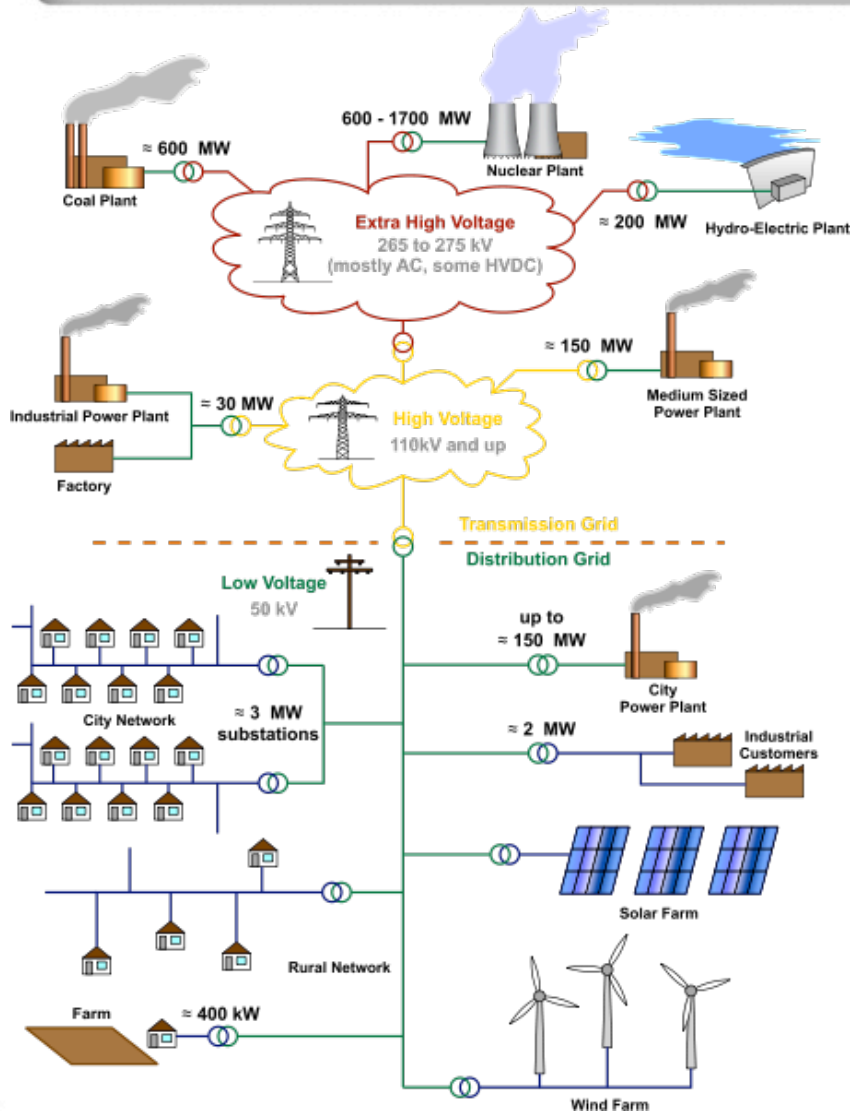

- Two interfaces: **HV/MV** and **MV/LV**
- Bidirectional jumps of voltage (step-up and step-down)
- HV and MV substations are grid nodes
- Presence of **protective relays** stops fault propagation and damages
- Energy **routing** is influenced by circuit breakers state (**switchgear**)

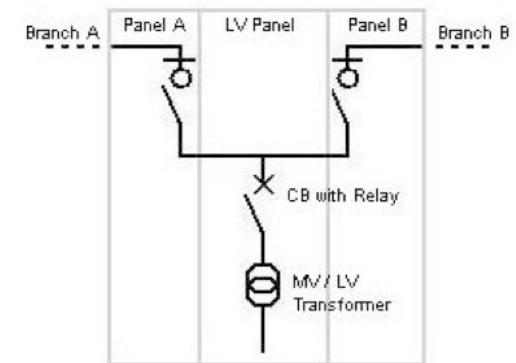

Transformers

- Used to step the voltage up or down

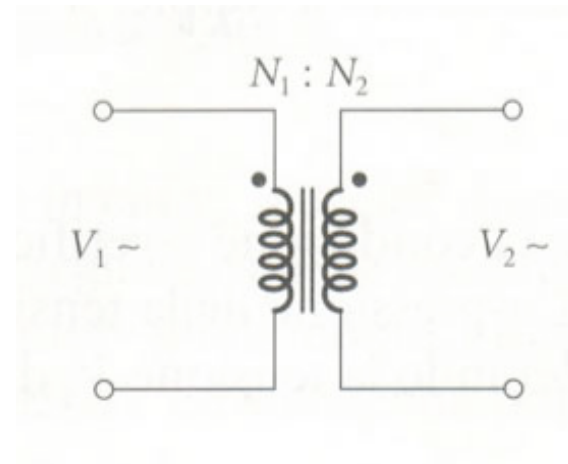
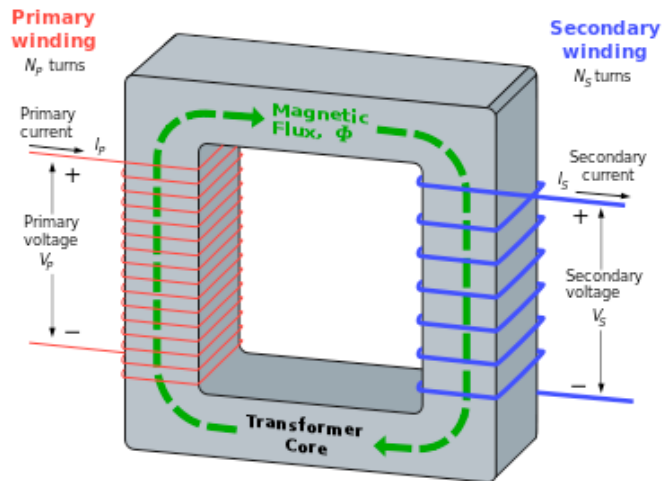

- Changing magnetic field within a coil of wire induces a voltage across the ends of the coil
- The right transformer can step the voltage with high efficiency

Protective relays

- A Relay is an electrically operated switch
- Designed to calculate operating conditions on an electrical circuit and **trip** circuit breakers when a **fault** is detected
- Well-established, selectable, time/current (or other operating parameter) operating characteristics



Loads classifications:

- Active loads are resistive and use **real power**

$$\langle P \rangle = V_{\text{rms}} I_{\text{rms}} \cdot \cos \varphi$$



- Passive loads are inductive or capacitive and use **reactive power** (not only)

$$\langle Q \rangle = V_{\text{rms}} I_{\text{rms}} \cdot \sin \varphi$$

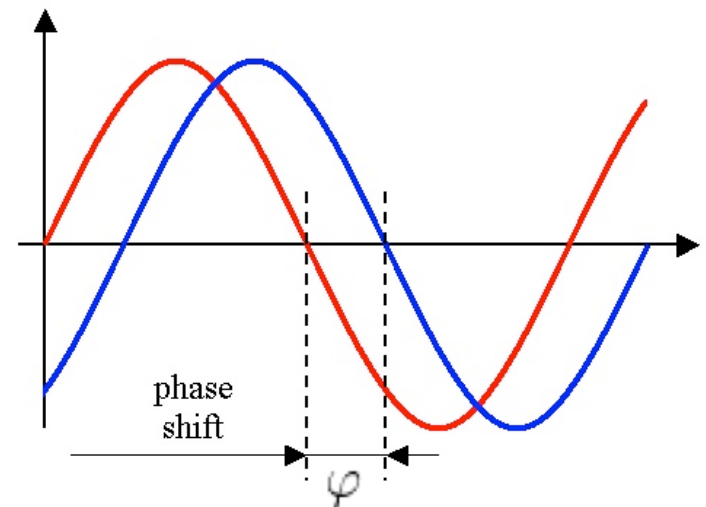

Phase shifts

- Phase jumps happens in many cases:
 - flow through an **inductor** or **capacitor**

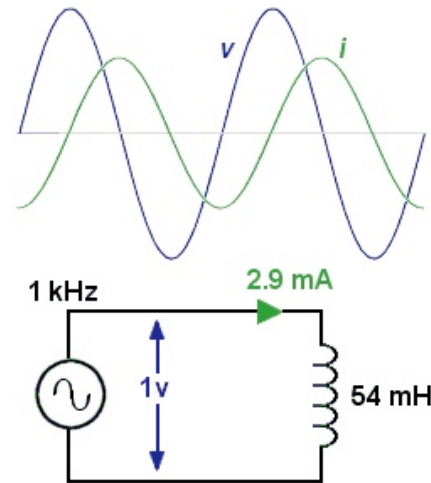
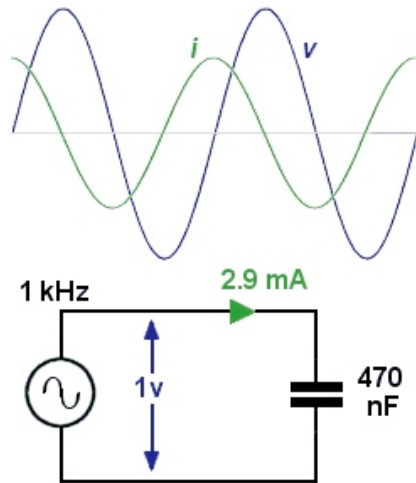

- occurrence of a **short circuit** fault

Reactive power

- **Apparent** power is provided by the energy supplier
- $P_{\text{Apparent}} = P_{\text{Real}} + P_{\text{Reactive}}$
- Real power actually performs the work
- Reactive power maintains the electromagnetic field of components (and is not effectively consumed)
- If a certain amount of P_{Real} is required:
 - strongly reactive power line --> more P_{Apparent} is needed
- What is Reactive power?

The water tower example (1/6)

- Analogy to explain the reactive power

The water tower

suppose a water tower and men that have to bring the water to the tank by climbing ladders. After emptying their bucket, they return by another ladder

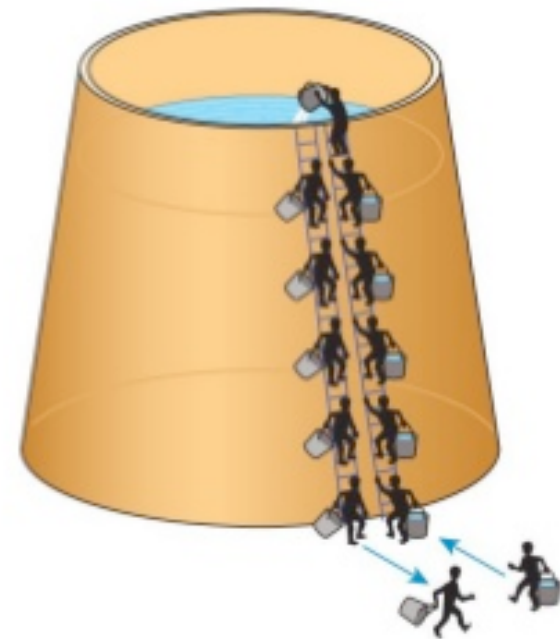

The water tower example (2/6)

Climbing ladder = Electricity line
Number of men = Voltage
Amount of water for each man =
Current
Amount of water added to the tank
per time interval = Frequency

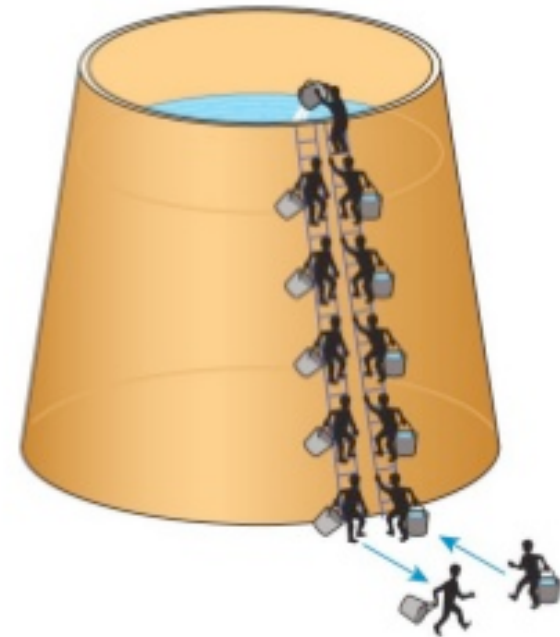

The water tower example (3/6)

Energy = Voltage x Current

Real power = height of the tower

If the tower is high (high power), there are two solutions to keep the frequency:

- using more man (higher voltage)
- increasing the amount of water each man carries (higher current)

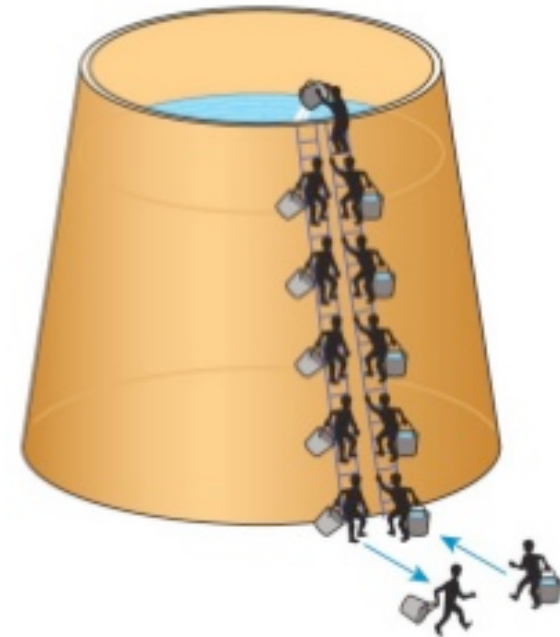

The water tower example (4/6)

If there are three ladders?

Three phases

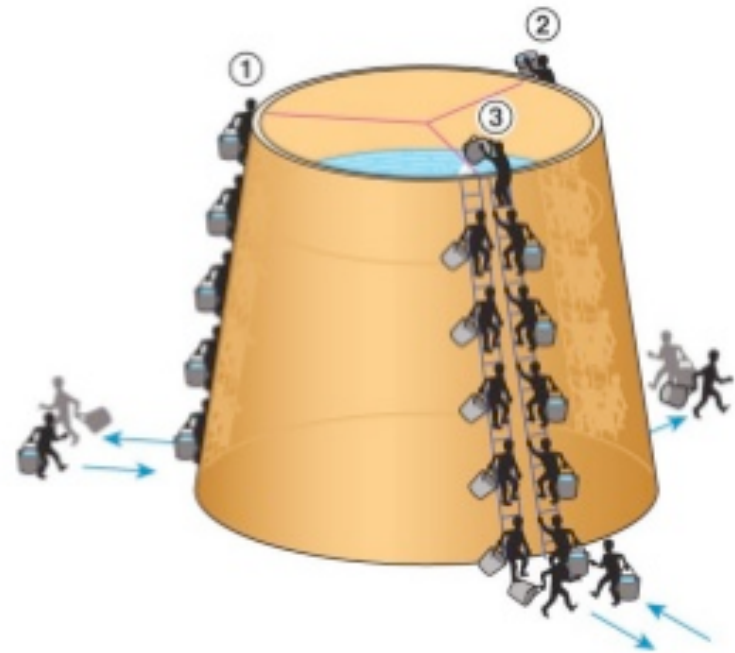

The water tower example (5/6)

Reactive power = width of the tower

Consequence: the length of the ladder (apparent power/voltage) depends on the height of the tower (active power) and the width of the tower (reactive power)

The higher the reactive power, the longer the ladder.

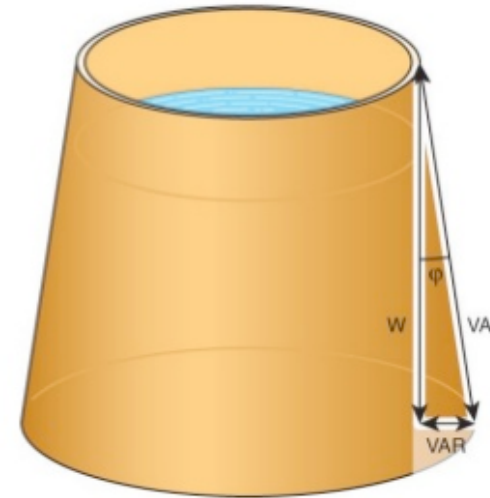

If the same voltage is kept (same amount of men on the ladder) each man has to bring more water to keep the same frequency

The water tower example (6/6)

- If a man is carrying more water (higher current) he will lose some along the way. **More reactive power means more losses**
- If the reactive power is so high that the men have to carry really a lot of water, one of the man could **collapse** --> the other men have to carry even more water --> if no support from new men is given, the system risks to experience a complete breakdown

International standards

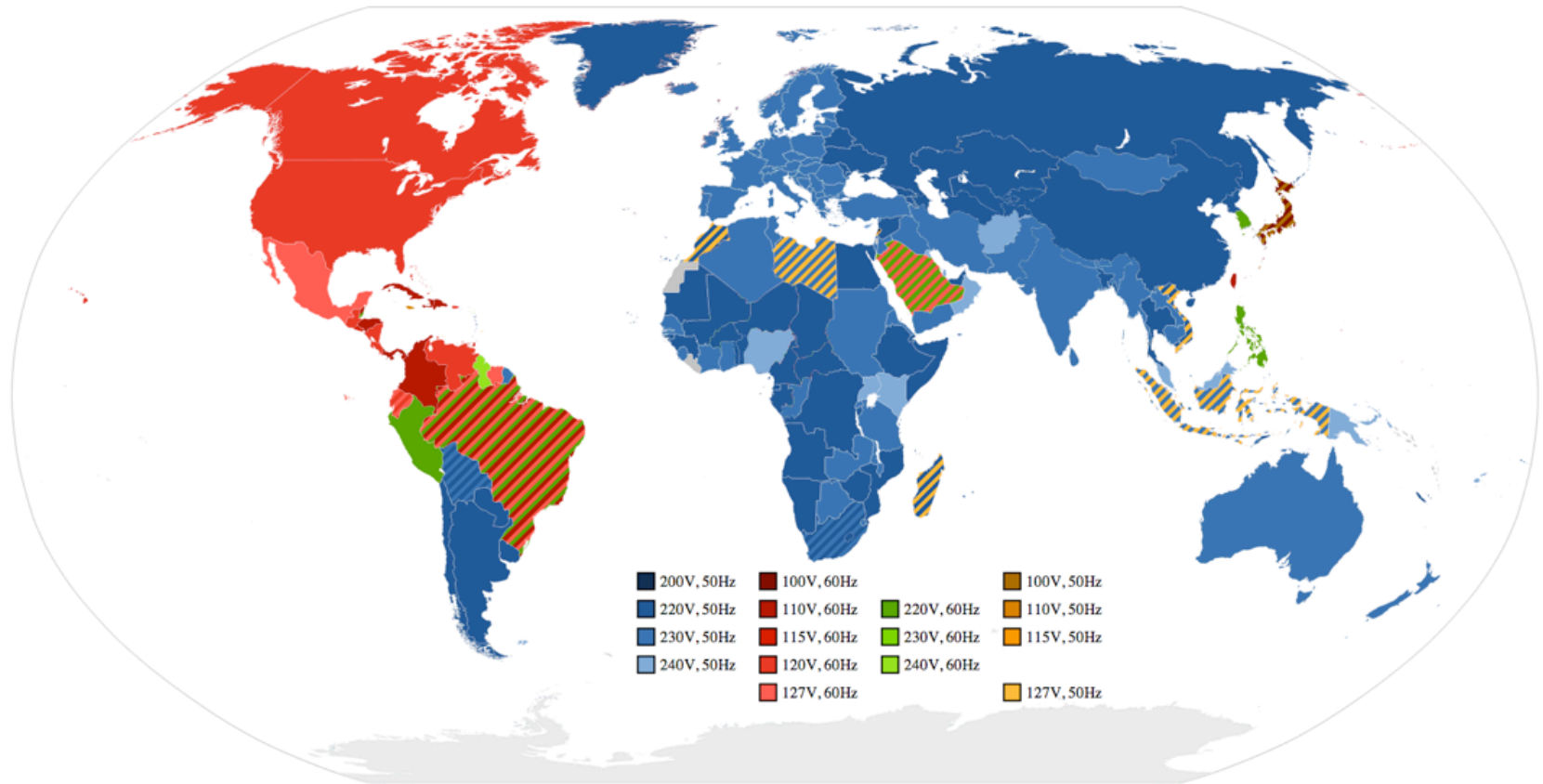

- **Italy:** three-phase voltage of 400 volts and a single-phase voltage of 230 volts (frequency 50 Hertz)

An obsolete grid...

- **Old and Outdated**
- Backbone is not ready for intermittent power sources (solar and wind)
- Disproportionately coal-friendly
- Politic is used to influence energy management

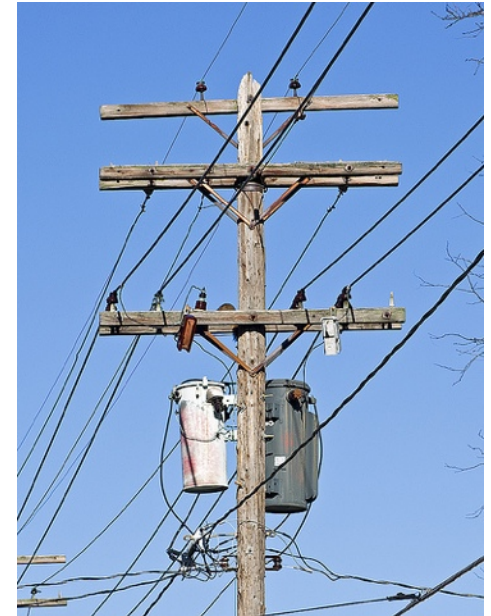

Evolution to SMART GRIDS

- A network of integrated microgrids that can monitor and heal itself
 - *Internet experience applied to the electric network*
- Supported by EU by the **20-20-20** directive (to be accomplished by 2020):

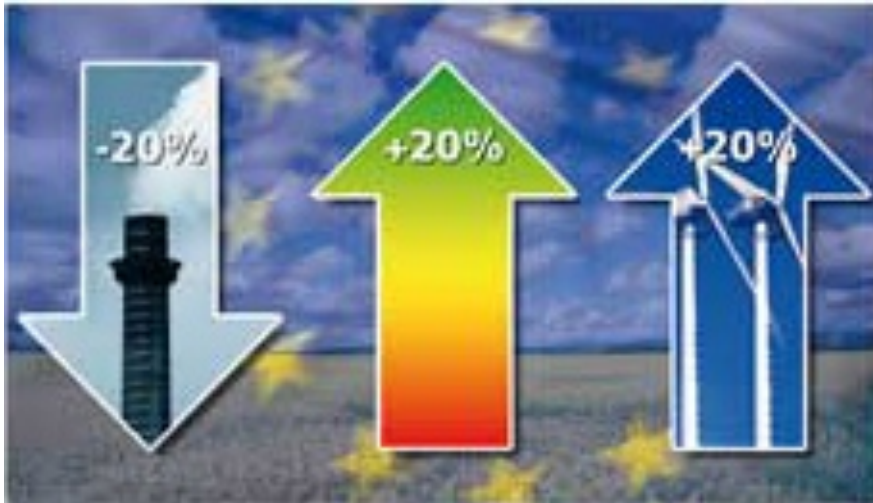

- A 20% reduction in EU greenhouse gas emissions from 1990 levels
- Raising the share of EU energy consumption produced from renewable resources to 20%
- A 20% improvement in the EU's energy efficiency

An equipped network

SMART GRID

A vision for the future — a network of integrated microgrids that can monitor and heal itself.

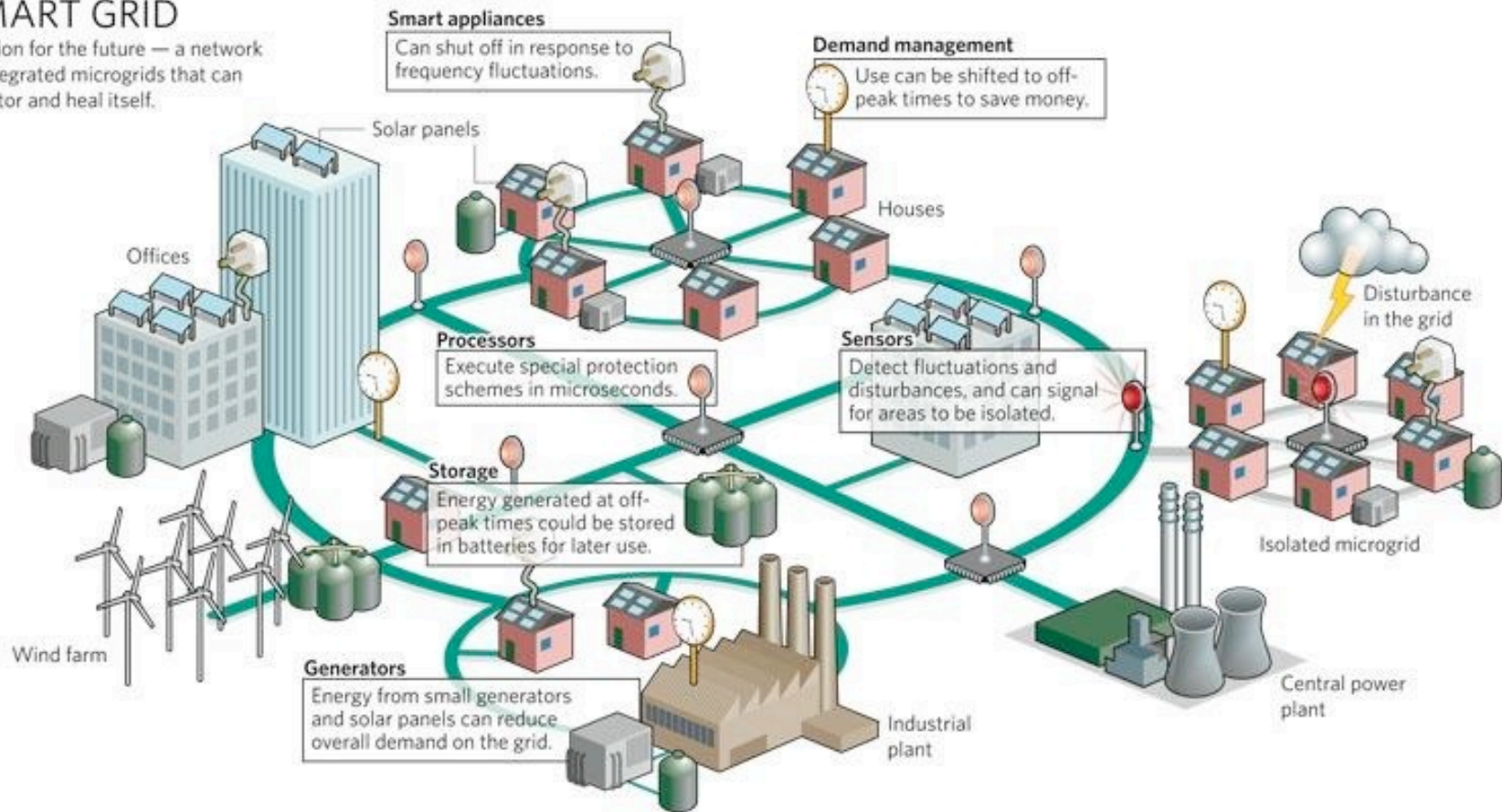

The technology behind...(1/2)



- Use of modern equipment for:
 - **Sensing & Metering**
 - *Advanced microprocessor meters (smart meters)*
 - *Wide-area monitoring systems*
 - *Dynamic line rating*
 - *Electromagnetic signature measurement/analysis*
 - *Time-of-use and real-time pricing tools*
 - **Integrated communications**
 - *SCADA (Supervisory Control And Data Acquisition)*
 - *Ethernet and industrial bus protocols*
 - *Wireless communication over Gprs/3G/4G*
 - *GPS positioning*
 - *Powerline*

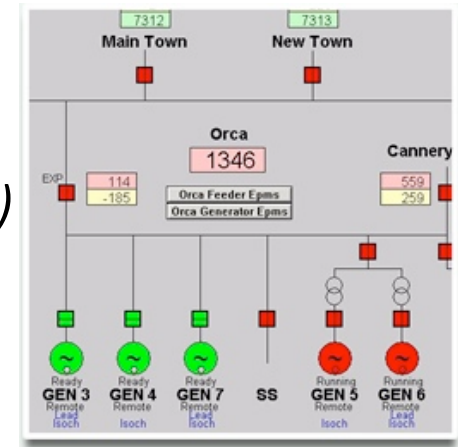

The technology behind...(1/2)

- **Processing**

- *Real time capabilities*
- *Distributed optimal decision protocols*
- *Artificial intelligence programming techniques*
- *Support for monitoring*
- *Transmit and organize data*

- **Storage and management**

- *Data servers*
- *Offline data analysis*
- *Storage facilities*

- **Renewable generation**

- *Wind turbines and solar cells*



Ultracapacitors

- fast charging
- fast discharging (on demand)
- 100% re-usable

Smart grid features (1/2)



- Reliability
 - Fault detection and self-healing of the network without the intervention of technicians
 - *short circuit faults*
 - *arc faults*
 - Remote control
- Flexibility in the network topology
 - handle possible bidirectional energy flows, allowing distributed and intermittent generation

Smart grid features (2/2)

- **Efficiency**

- demand-side management
- maximization of local power generation usage
- flow control
- **Load adjustment**
- **Peak leveling**
- Time of use pricing



“If you wait one hour you can wash for free!”

Example video

- Remote control decreases risks



Energy consumption: considerations

- **Reactive power** has to be as less as possible
 - Energy providers make the user pay the inefficiency of its power line
 - Phase shifts need to be compensated:
 - *Energy provider side compensation (price on the bill)*
 - *User side compensation (price on the equipment)*

Smart metering can help to understand the amount of reactive power that is effectively present in the user building

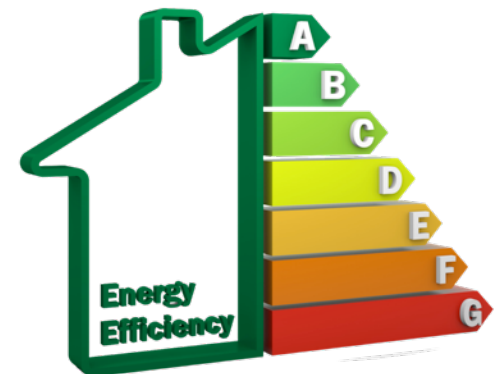

Energy saving: reactive power

- Capacitors can help to reduce reactive part of power

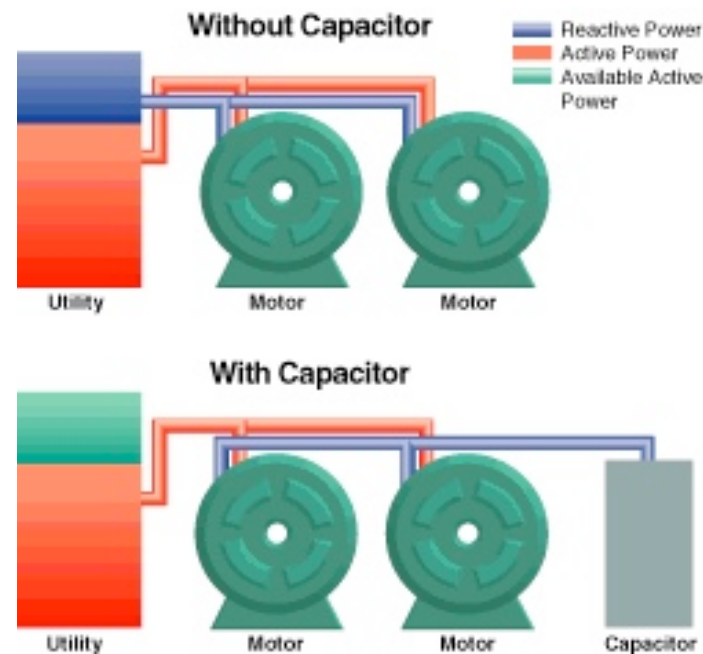

- A good knowledge of an energy network can help choosing the right size of the capacitors

Energy saving: reactive power



- Dynamic compensation is possible (with multiple capacitors) whereas the phase shift is highly variable

Energy consumption: considerations

- **Consumption peaks** should be avoided as much as possible (bet how much do you consume):
 - industries cannot experience blackouts
 - price for a consumption limit threshold (pass it means to pay a fee)
 - energy management should choose it very well

Smart metering can help to understand the consumption per device and the total amount of needed power

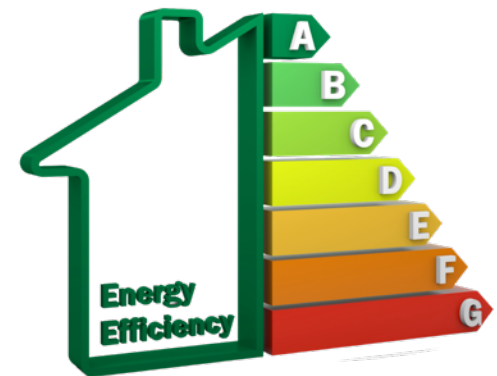

Peak leveling-shaving

- Consumption needs to be always under the threshold of supplied energy
- Storage in batteries is an opportunity when consumption is not uniform during time

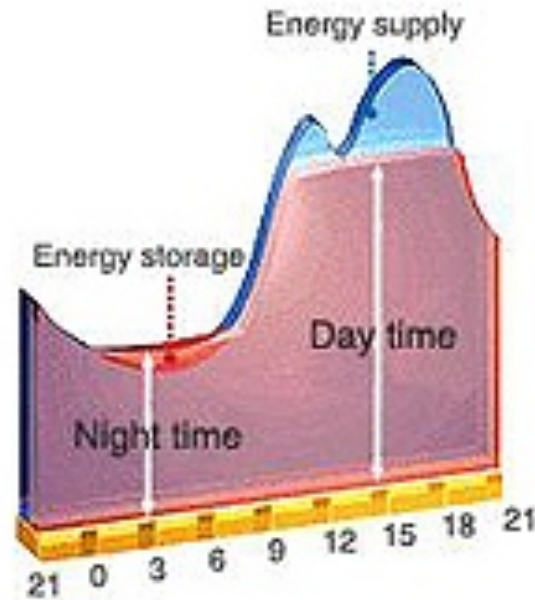

Load leveling

- The load appears constant from the provider side and always under the threshold
- Energy provided per time can effectively be as low as possible

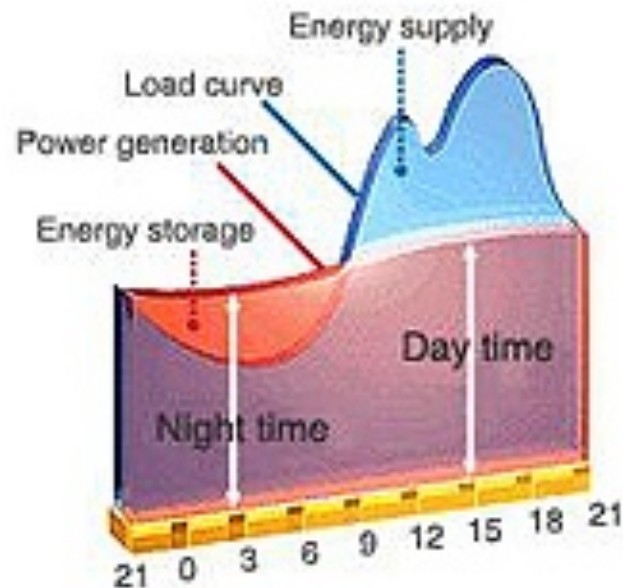

Energy consumption: considerations

- **Local power generation usage** should be maximized
 - Over-production is usually sold to the energy provider
 - Periods of high usage can make the user buying its energy back (losing money)
 - Microgrids should be autonomous as much as possible

Smart systems can help to understand the relationship between user consumption and production, suggesting a consumption schedule which prefers usage of power generated locally

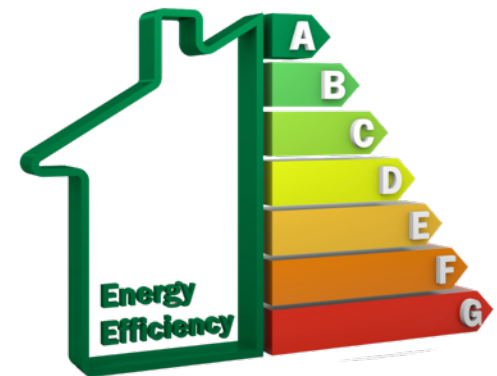

Self healing example: the network



- Medium Voltage Network
 - 10kV power lines
 - interface with High and Low Voltage areas
 - ring of substations (typically 11)
 - current flow in and out substations
 - switching capability
 - double powered
 - double current flow (converge to a middle point)

Self healing example

- Medium Voltage Network

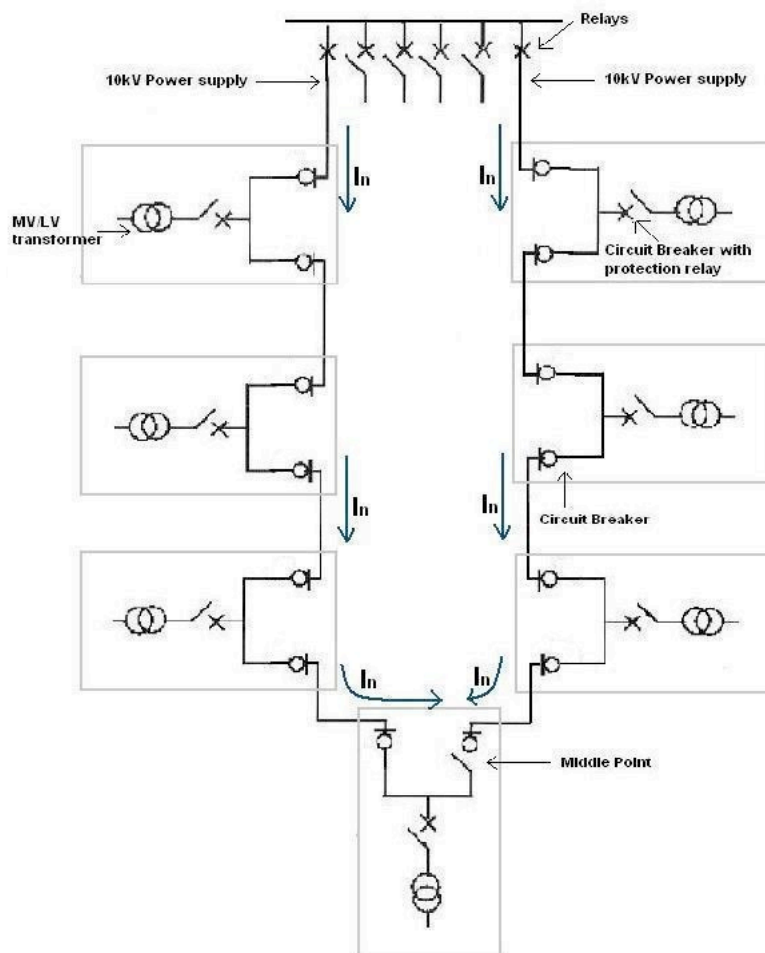

Digital I/Os



Medium voltage substation

- Up to 5 panels with Circuit Breakers
- Optional connections
 - Low Voltage area
 - other rings

Remote Terminal Unit

- Remote controlling via GPRS
- Communication with
 - other RTUs
 - other controllers

Self healing function (1/2)

- Automatic re-closure in case of Short Circuit
 - Automatic localization and isolation of the Fault location
 - Re-organization of the network after isolating the faulty area
 - Completely **distributed**
 - Uses **directional fault indication** of smart meters
 - Uses small communication between RTUs
 - Considers concurrency in case of double detections
 - Exchange of messages uses a Publish\Subscribe communication method

Self healing function (2/2)



- Advantages
 - Reclosure of the network in about one minute instead of an hour
 - Allows having a working network during maintenance periods
 - Does not affect real-time performance of the RTU
 - Reports events to help the maintenance procedures

Short Circuit Fault description (1/3)

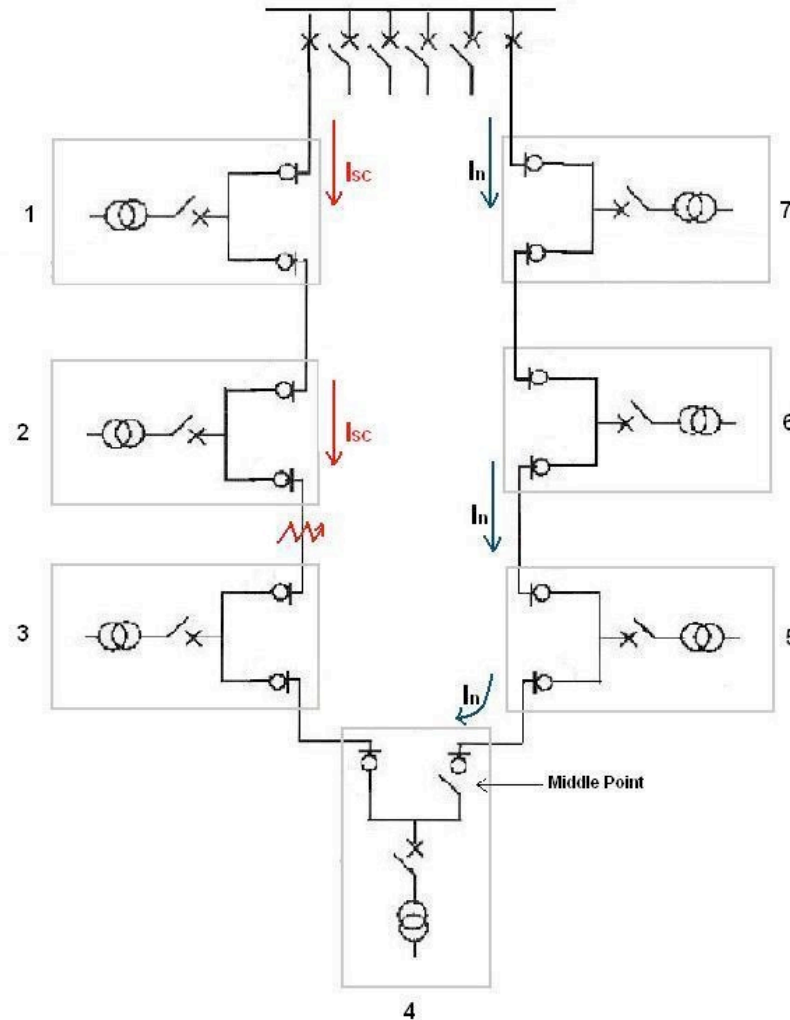

Short Circuit Fault description (2/3)

Half of the ring has no power anymore

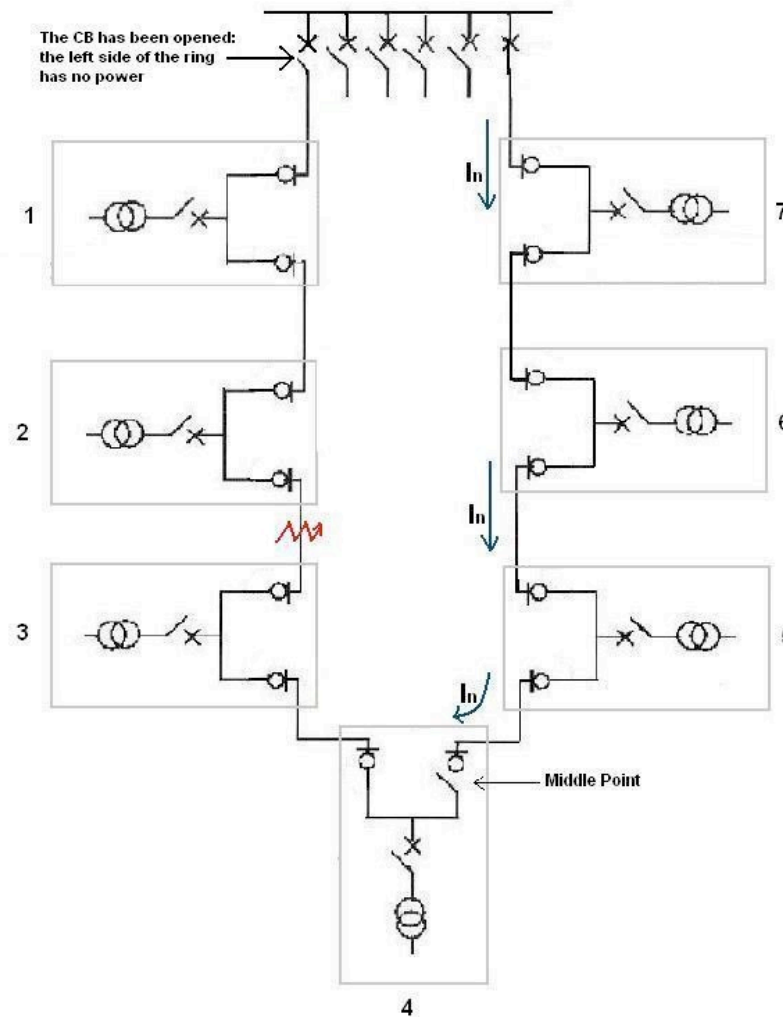

Short Circuit Fault description (3/3)

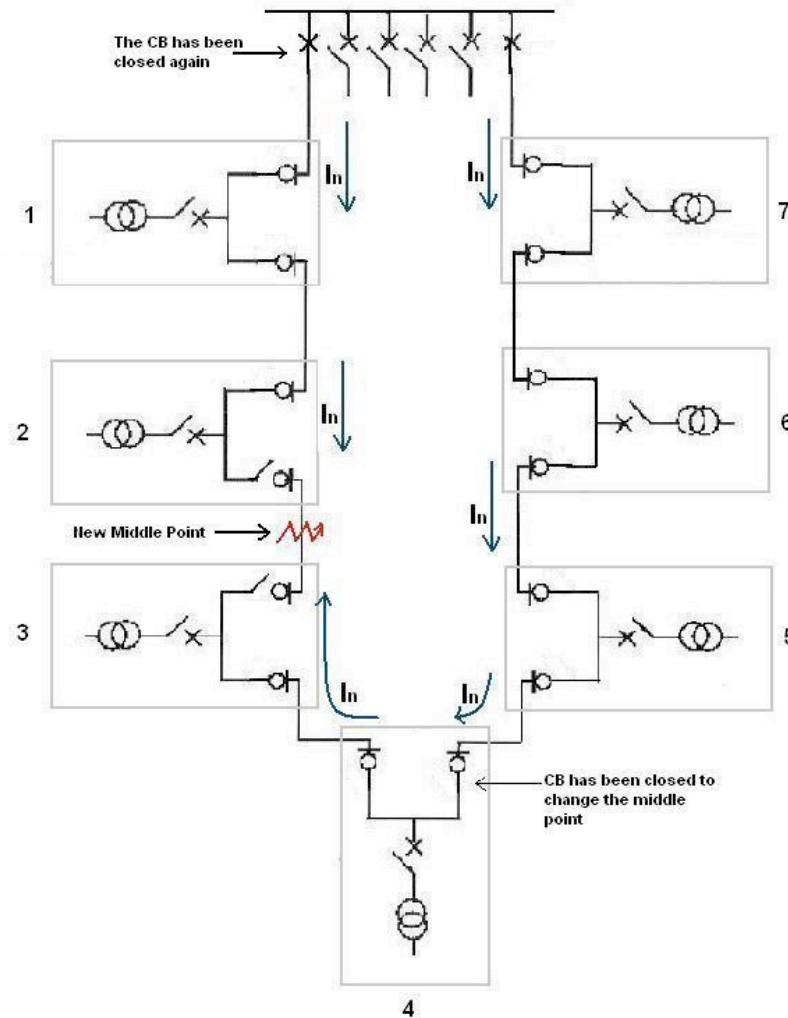

Localization method

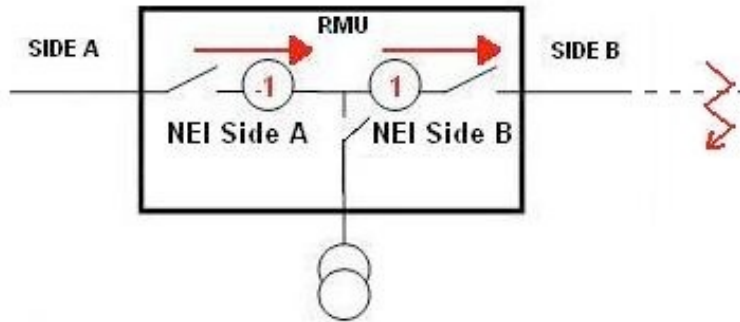

Directional Fault Indication (DFI) has output:
-1 short current is incoming to the panel
1 short current is outgoing from the panel

How to find the fault location?

2 NEI: Near End Indication (local DFIs)

2 FEI: Far End Indication (remote DFIs of Neighbors at side A and side B)

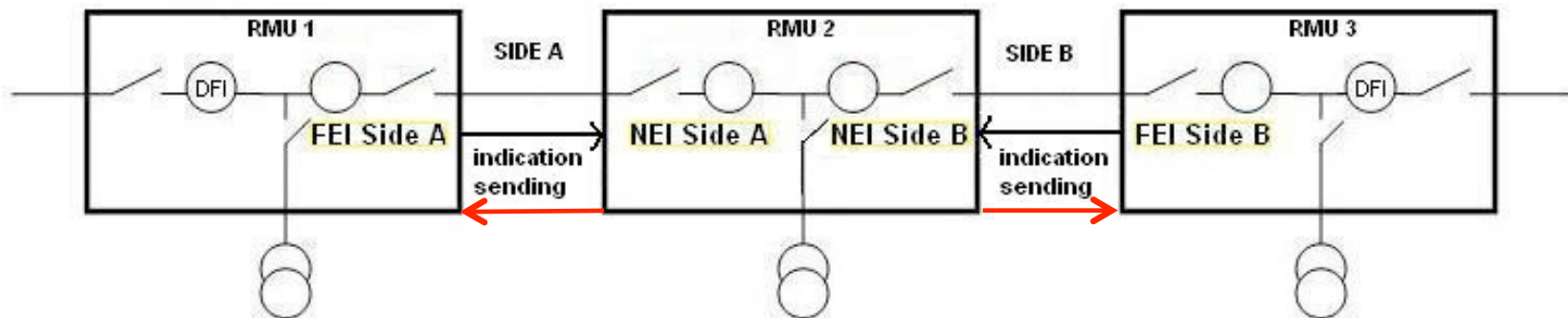

Localization method

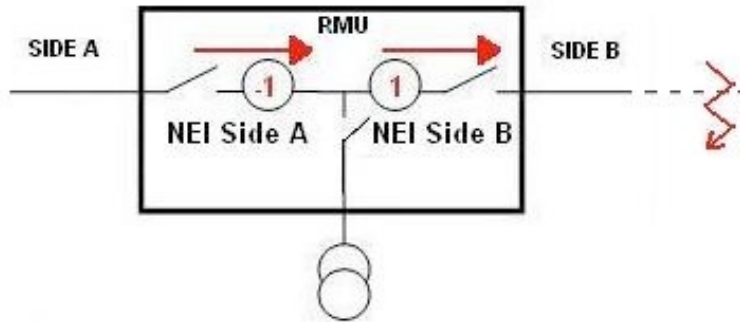

Directional Fault Indication (DFI) has output:
-1 short current is incoming to the panel
1 short current is outgoing from the panel

How to find the fault location?

2 NEI: Near End Indication (local DFIs)

2 FEI: Far End Indication (remote DFIs of Neighbors at side A and side B)

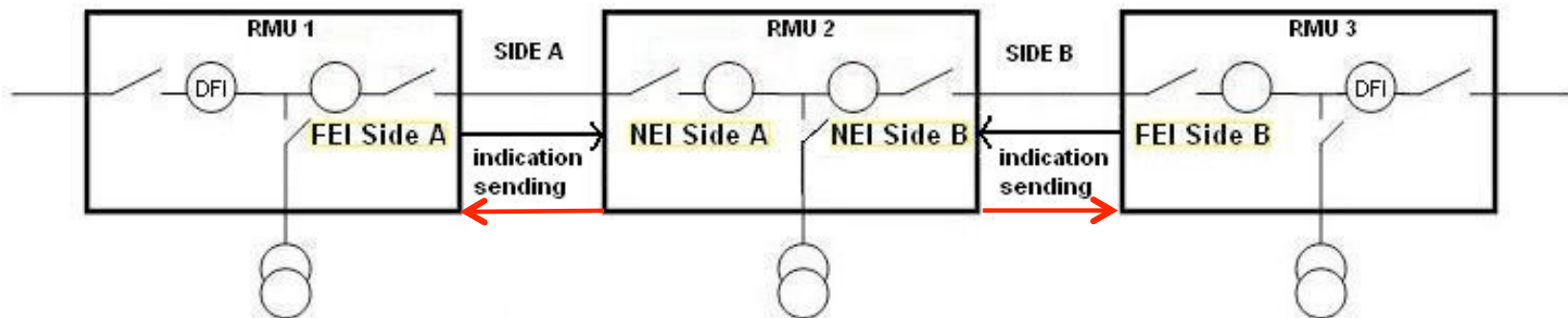

Neighbors exchange their DFI on every fault occurrence

Directional fault indication

- *Case 1: short circuit on side B of the unit*

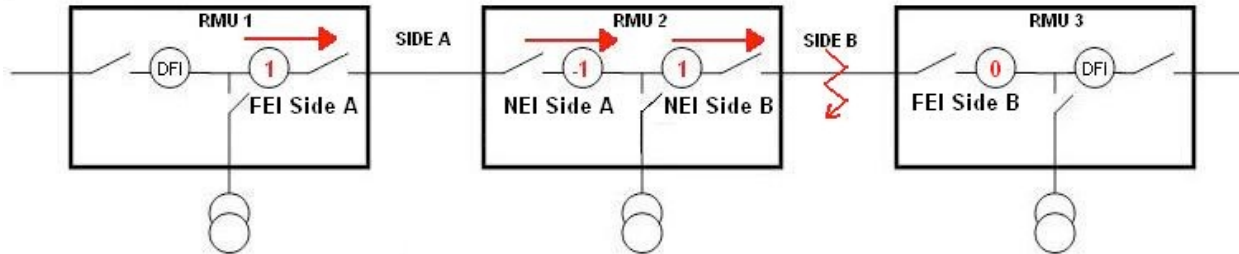

- *Case 2: different short circuit on side B of the unit*

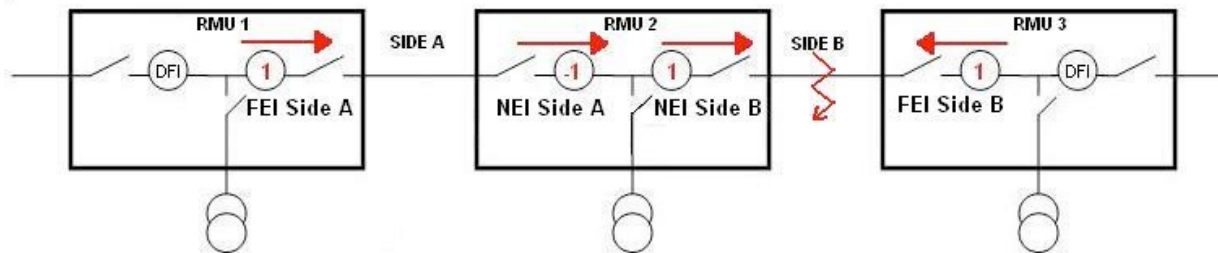

- *Case of short circuit in the LV area*

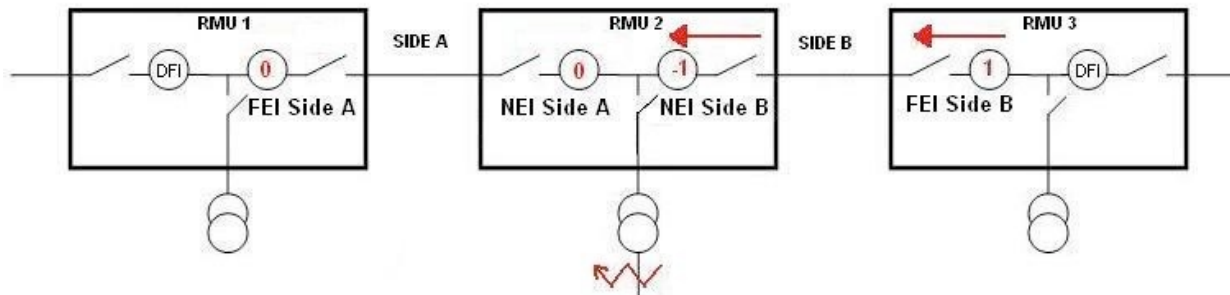

Message exchange

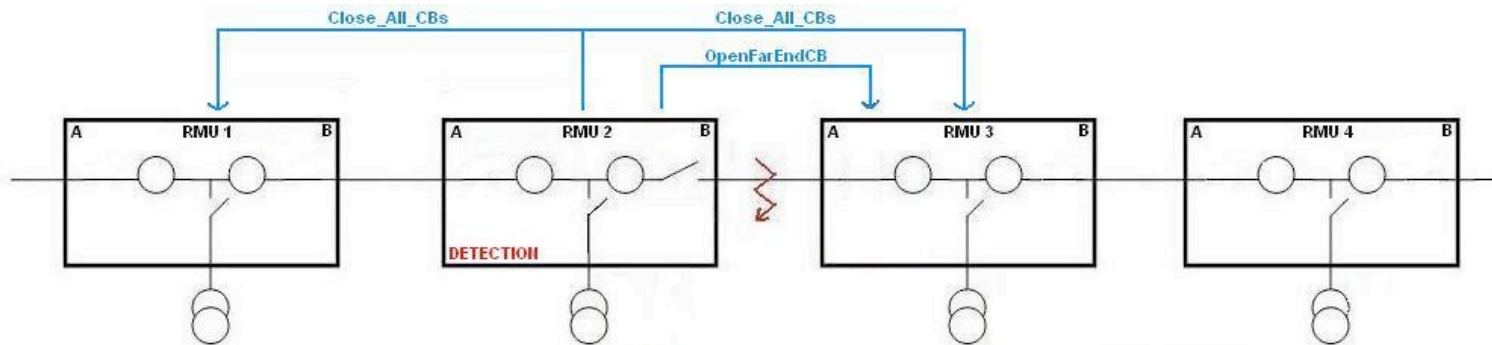

- Ring Main Unit 2 becomes starter of the reclosure procedure
 - Opens its CB on the faulty branch
 - Orders the neighbor on the faulty side to open its CB on that side
 - Orders to close all the CBs on both sides (to change the middle point)

Message exchange

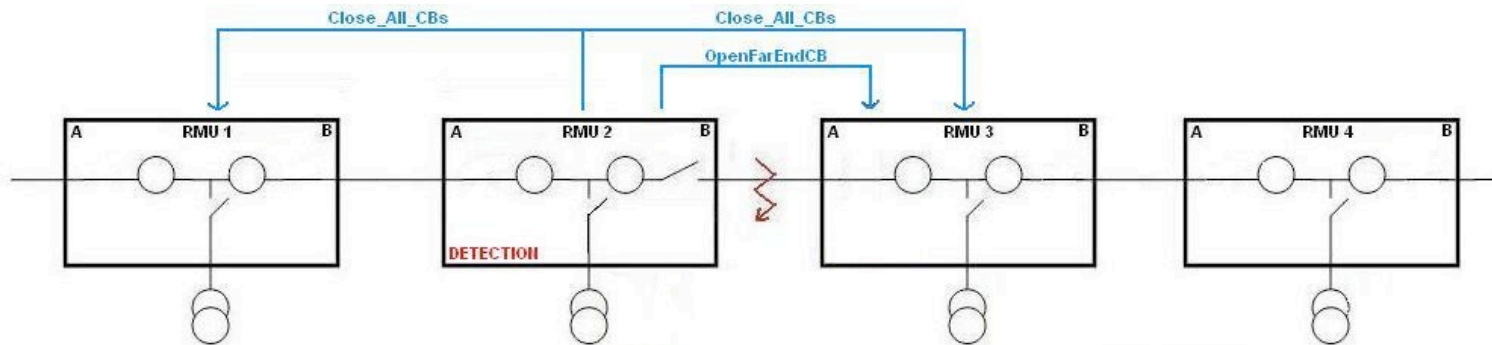

- Ring Main Unit 2 becomes starter of the reclosure procedure
 - Opens its CB on the faulty branch
 - Orders the neighbor on the faulty side to open its CB on that side
 - Orders to close all the CBs on both sides (to change the middle point)
 - Ring Main Unit 3 shares the faulty branch with Unit 2
 - Opens its CB on the faulty branch after receiving the order from Unit 2
 - Manages the request of closing all CBs (sends it again if it has not open CBs)

Message exchange

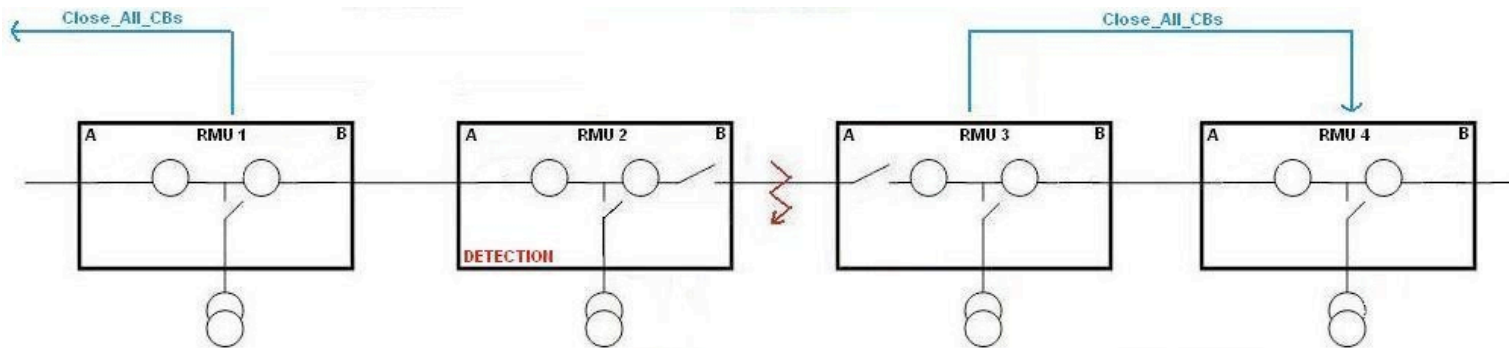

- Ring Main Unit 2 becomes starter of the reclosure procedure
 - Opens its CB on the faulty branch
 - Orders the neighbor on the faulty side to open its CB on that side
 - Orders to close all the CBs on both sides (to change the middle point)
 - Ring Main Unit 3 shares the faulty branch with Unit 2
 - Opens its CB on the faulty branch after receiving the order from Unit 2
 - Manages the request of closing all CBs (sends it again if it has not open CBs)
 - Request of closing all CBs stops propagating when a open CB has been found
 - **N.B. Request goes on both directions from the fault detector**

Concurrency (1/3)

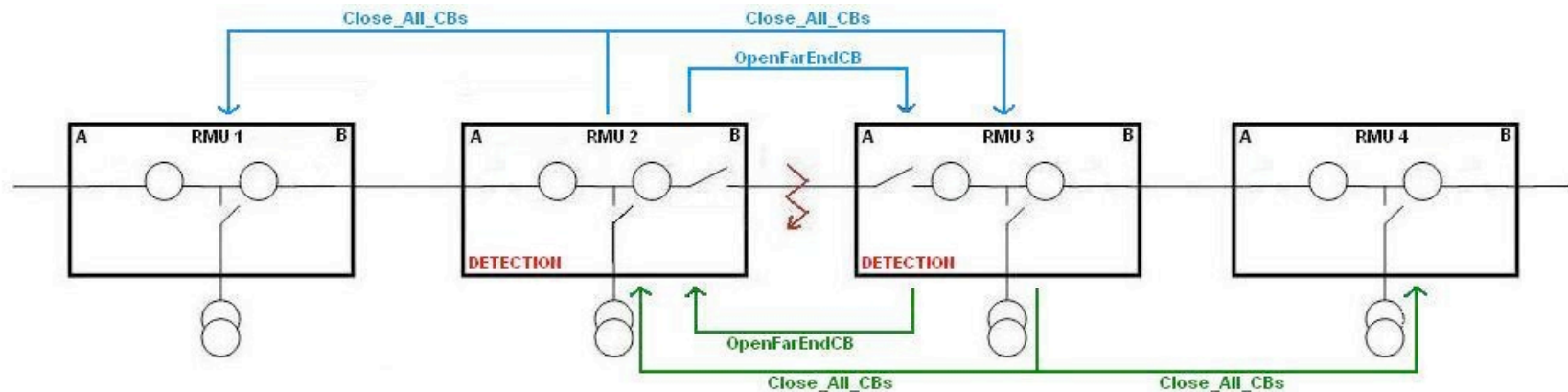

- Double detection of the fault
- Starting of two symmetric message exchange schemes
- Could cause incorrect network states

Concurrency (2/3)

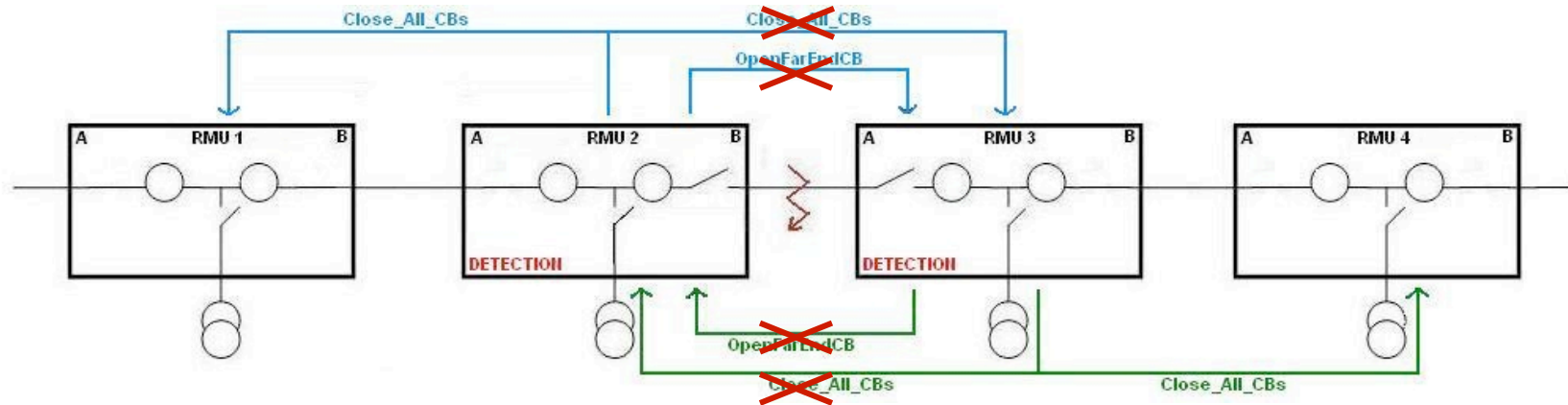

- Double detection of the fault
- Starting of two symmetric message exchange schemes
- Could cause incorrect network states
- Key point: detection is always faster than communication
- Detection state modifies message management
- Symmetric requests between detecting units are ignored

Concurrency (3/3)

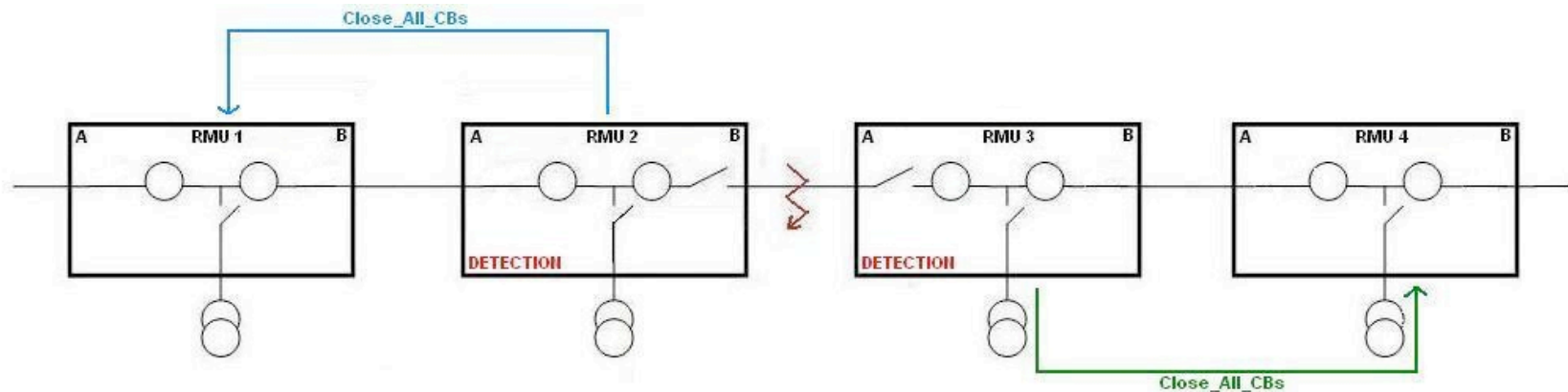

- Double detection of the fault
- Starting of two symmetric message exchange schemes
- Could cause incorrect network states
- Key point: detection is always faster than communication
- Detection state modifies message management
- Symmetric requests between detecting units are ignored
- After solving the concurrence, research of the middle point works normally
- Each unit sends the research message on its side sub-network

Thanks

Rodolfo Pallotta - Over Srl

tel: +39 06 80368933

skype: r.pallotta.over

r.pallotta@overtechnologies.com

